

Hydrogen burners for industrial decarbonization

Be ready now for the revolution in combustion technology!

SAACKE

H₂
ready



Introduction

In the public debate, hydrogen (H₂) has advanced to become the bearer of hope in the energy mix of the future, because its potential in the hard-to-decarbonize industry (steel, cement, chemicals) and mobility (ships, air traffic, automotive) is enormous. Unlike electricity from the sun and wind, H₂ can be easily stored - as gas or in liquid form. In summer 2020, the German Federal Government adopted the "National Hydrogen Strategy" and the EU Commission is aiming for a true systemic change with its Green Deal:

By 2030, 40% less CO₂ is to be emitted and by 2050 Europe is to become a climate-neutral continent.

By 2024 the production of clean hydrogen is expected to increase to one million tons, and by 2030 to ten million tons. In this way, H₂ should not only be the lifeline for climate and energy transition, but also a growth engine for technical innovation.

A bluish transparent hydrogen flame on a Low-NOx hydrogen burner from SAACKE.

Technology is proven and immediately available

To integrate hydrogen into the energy mix requires experience and specific know-how. SAACKE, as a technology leader, has been manufacturing Low-NOx combustion systems for several decades, also in connection with hydrogen, i.e. "H₂ ready". We can immediately support you in switching to H₂-based heat generation in order to use the potential of a climate-neutral and ultra-modern energy economy. This is where we come into play,

where there is viable technology for the efficient processing of large quantities of "blue" or "green" H₂ in industrial thermal processes. And this is already the case today - for example as a waste material in the chlor-alkali industry or titanium dioxide production as well as in propulsion and heating systems on ships. Here, using the existing H₂ instead of additional natural gas or marine diesel oil, saves not only emissions but also costs.

H₂ injection into the natural gas network - ensuring operational safety

The volume of H₂ as a complementary fuel to natural gas will increase significantly. In the coming years, experts expect the permissible H₂ content added to the existing natural gas network to increase to up to 20 %. Two thirds of the current German natural gas infrastructure could be used for hydrogen

admixtures in the future. This places demands on plant operators and the technology itself. Those who use an H₂-compatible burner today avoid having to retrofit in the future and ensure the long-term operation of their plants.

Excursus on hydrogen

What are the characteristics of this promising energy source, in which variants does it exist and what else is there to consider?

A brief overview

Types of hydrogen

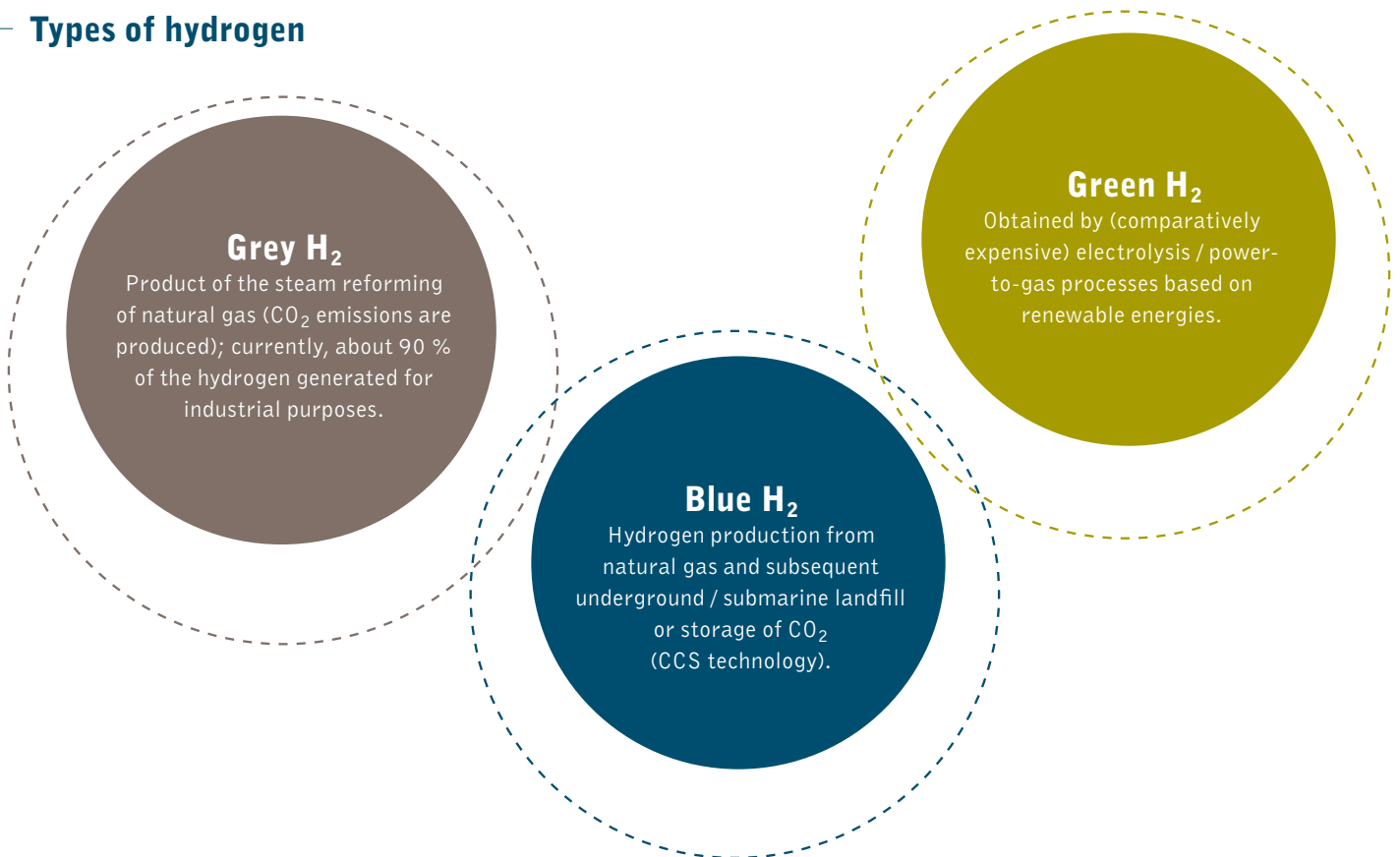

Characteristics of hydrogen combustion

- The H-atom is the lightest and smallest element of the periodic table
- H₂ is colorless, odorless and tasteless
- It is 8 times lighter than natural gas
- The calorific value is lower by a factor of 3 to 3.5 than most commercially available natural gases
- The flame burns about 8 times faster than natural gas
- Extremely wide flammability range (4-77 vol% compared to 4-16 vol% for natural gas)
- 15 times less spark energy required for ignition than natural gas (0.02 mJ)

Facts and figures

- The German government is planning a program for the development of H₂ production plants; by 2030, industrial production plants with a total capacity of up to 5 GW should exist (including the necessary offshore and onshore energy production); another 5 GW are planned by 2040 at the latest.
- The production of green hydrogen, which is exempt from the EEG levy, is being sought and the promotion of "H₂-ready" plants via the CHP Act is being examined.
- The power requirement for the production of hydrogen is enormous. For Germany alone, some scenarios forecast an additional 450 terawatt hours - that is more than 2.5 times as much as was produced from lignite and hard coal together in Germany in 2019.
- H₂ holds enormous potential for environmental protection - calculation example: A 7.5 MW burner that runs continuously at maximum output (24 hours/day) and is converted to hydrogen saves around 35 tons of CO₂ emissions per day compared to natural gas combustion.

The power-to-gas process - how green H₂ is produced

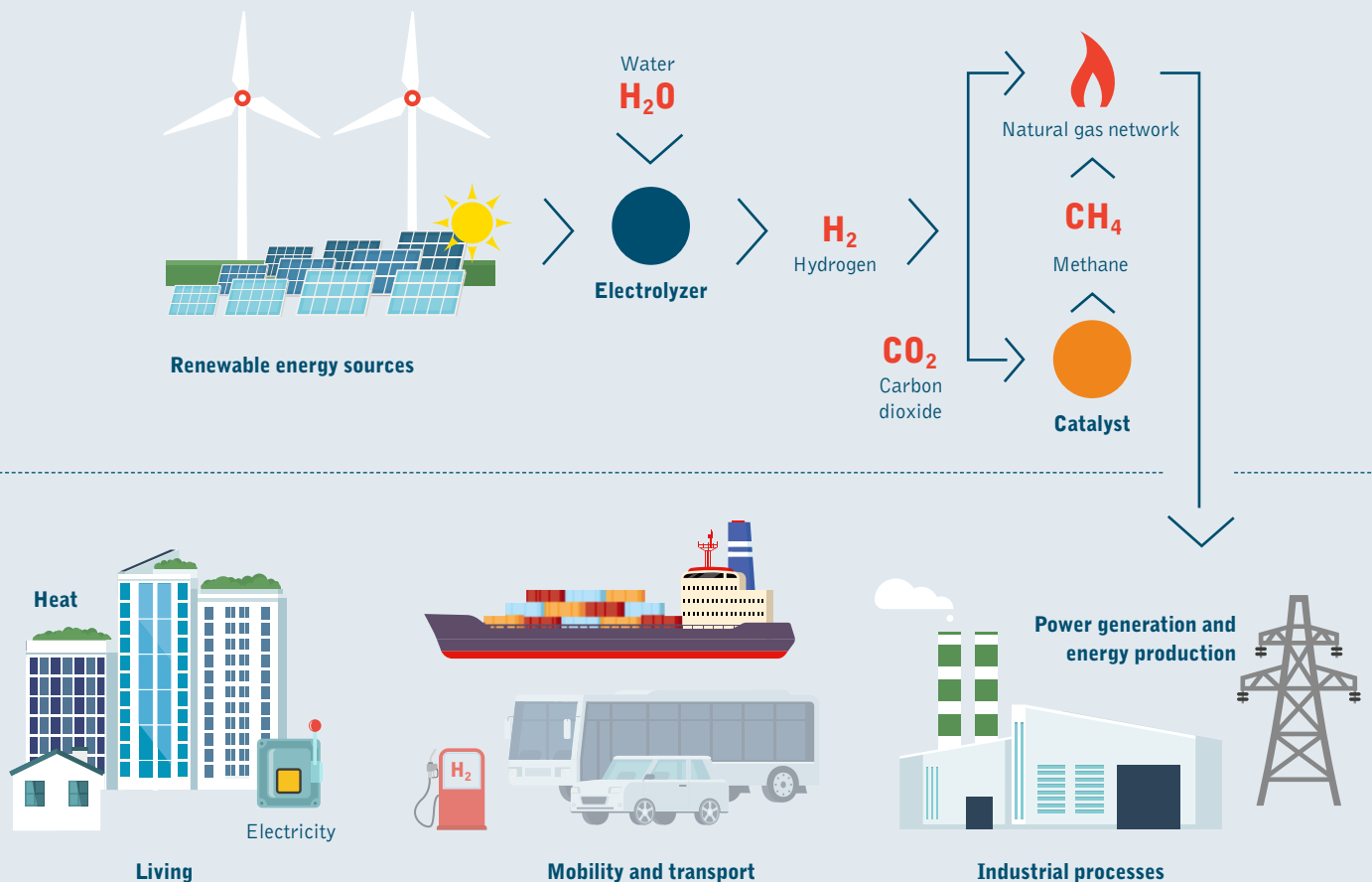

The SAACKE solution in detail

SAACKE has been researching in the field of H₂ for about 40 years and, thanks to this technological advantage, **is one of the few suppliers worldwide that can already offer safe and Low-NO_x hydrogen burners on the market today and provide CO₂-neutral heat** - both in industry as well as in

maritime shipping. Due to the experience in special plant engineering, SAACKE can offer a wide range of natural gas-based burners for steam generation, which can use alternative fuels such as H₂.

SAACKE burner type	"H ₂ ready" up to...
TEMINOX	20 Vol.% hydrogen content
ATONOX	20 Vol.% hydrogen content
SKVG	100 Vol.% pure hydrogen by means of multitools
SSBG	100 Vol.% pure hydrogen by means of multitools

Your One-Stop-Shop

With us, you get everything from one source, because we are your One-Stop-Shop for complete H₂ combustion systems - whether engineering, assembly, retrofit or spare parts service.

Our unique selling proposition

Our technological advantage lies in a sophisticated flue gas recirculation and the special design of the gas injection. These two key components ensure that the higher flame temperature and up to 3 times higher NO_x emissions from the combustion of hydrogen compared to natural gas are minimized to similar levels.

The SAACKE complete solution

- CFD Analysis
- Combustion chambers and burners
- Flame monitoring systems and burner controls
- Fuel/air control systems
- 24/7 remote monitoring (on request)

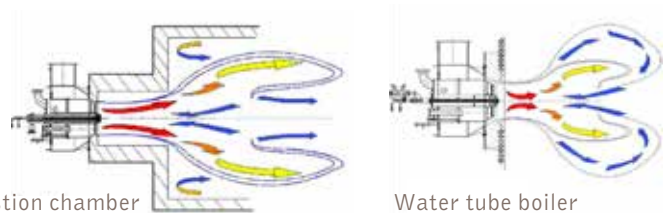
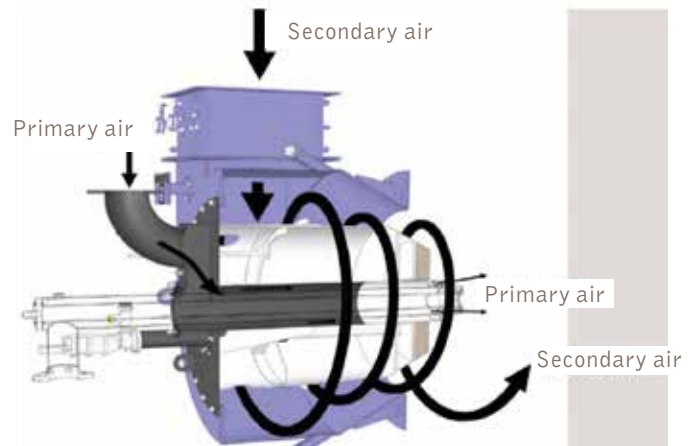

Short and concise: The challenge and the technical solution

Task

Future-proof combustion of hydrogen while maintaining low emissions and a stable flame temperature.

Solution

Ultra-low NOx-burners with sophisticated flue gas recirculation and a special gas injection design based on decades of experience and engineering competence.



Most important industries for hydrogen burners (excerpt)



Refineries



Chemical industry



Automotive industry



Textile and paper industry



Steel and metal production



Food industry



Building materials industry



Energy and heat supply (operators of boiler plants and district heating networks of any kind)



Shipping

SAACKE references

40 years ago, H₂ was still an exotic fuel. However, since the number of concrete project inquiries has steadily increased in recent years, SAACKE has so far commissioned about 30 H₂ combustion plants, for example in the chemical industry for steam generation or for hot water for district heating. In Chi-

na, there are about 20 SAACKE burners based on natural gas, which achieve emissions < 30 mg/m³ NO_x. These Ultra-low NO_x-burners could also be converted to hydrogen operation at any time.



Project example on land

The Audi e-gas plant in Werlte in northern Germany was the first industrial-scale plant in the world to generate synthetic natural gas that could be fed into the grid from CO₂ and renewable electricity. The methane produced is fed into the natural gas network and used as fuel (Audi e-gas). The CO₂ required for the methanation comes from an on-site biogas plant. The resulting energy carriers hydrogen and methane can be used in a wide variety of ways - in the case of the Werlte plant, up to 1,300 cubic meters of water can be used per hour.



With an assumed operating time of 4,000 full-load hours, this produces almost 1,000 tons of methane per year - a quantity that can be used to power 1,500 CNG vehicles in the compact class (e.g. Audi A3 g-tron) for 15,000 km each. In this case, the production of this energy source known as e-gas binds around 2,800 tons of CO₂ per year. That is as much as a forest with about 200,000 deciduous trees can absorb. The waste heat from the power-to-gas plant, which is generated during electrolysis and subsequent methanation, can be used for the heat requirements of the biomethane plant. This heat demand is especially generated during CO₂ separation and hygienization of the delivered bio-residues. SAACKE supplied an SSBG 10 burner with se@vis pro burner control for this project, which is operated with biogas or biogas/H₂ mixture.



Project example on water

The world's first liquid hydrogen tanker, christened "Suiso Frontier" in Japan in December 2019, is equipped with a hydrogen-compatible and patented Gas Combustion Unit (GCU) and a SSBG burner from SAACKE. They ensure that the LH₂ can be transported by sea as safely as liquid natural gas. The ship is operated by the Hydrogen Energy Supply-chain Technology Research Association (HySTRA), a consortium of several companies and organizations founded four years ago under the leadership of Kawasaki Heavy Industries, Ltd. The aim of the pilot project is to demonstrate the smooth operation of an international hydrogen energy supply chain from production to transport and utilization. So-called "blue" hydrogen produced and liquefied in Australia, with on-site carbon capturing, is to be shipped to Japan in large quantities with 1/800 of its original volume. The GCUs burn excess boil-off gas in large quantities and with maximum availability. These gases are produced by slight evaporation during the crossing. In the SAACKE 100% free-flow solution, the boil-off gas is completely combusted without a compressor and already at a pressure of 0.15 bar.



Extract of the SAACKE reference overview

Plant / Operator	Country	Heat generator power	Number of burners	Fuel 1	Fuel 2	Order year
Suiso Frontier	JAP		1	Hydrogen		2019
Halo Polymere	RUS	8,0 MW	1	Hydrogen	Natural gas	2017
AGC Chemicals	THAI	5,0 MW	1	Hydrogen	Natural gas	2016
Vapormat / Ehersa	ESP	4,5 MW	1	Hydrogen	Natural gas	2015
Changzhou Zongyan	CHN	4,5 MW	1	Hydrogen	Natural gas	2014
CHEMFAB India	IND	3,0 MW	1	Hydrogen	HFO	2013
Akzo Nobel Ibbenbüren	GER	5,7 MW	1	Hydrogen	LFO	2012
Esso Slagen / Metso	SWE	10,3 MW	6	Hydrogen	LFO	2007
Akzo Nobel Ibbenbüren	GER	6,0 MW	3	Hydrogen	LFO	1992
Finnish Chemicals, Äetsä	FIN	15,0 MW	1	Hydrogen		1978
Finnish Chemicals, Joutseno	FIN	10,8 MW	1	Hydrogen	LFO	1975

If you are interested in further projects or specific details, please contact us at H2@saacke.com.

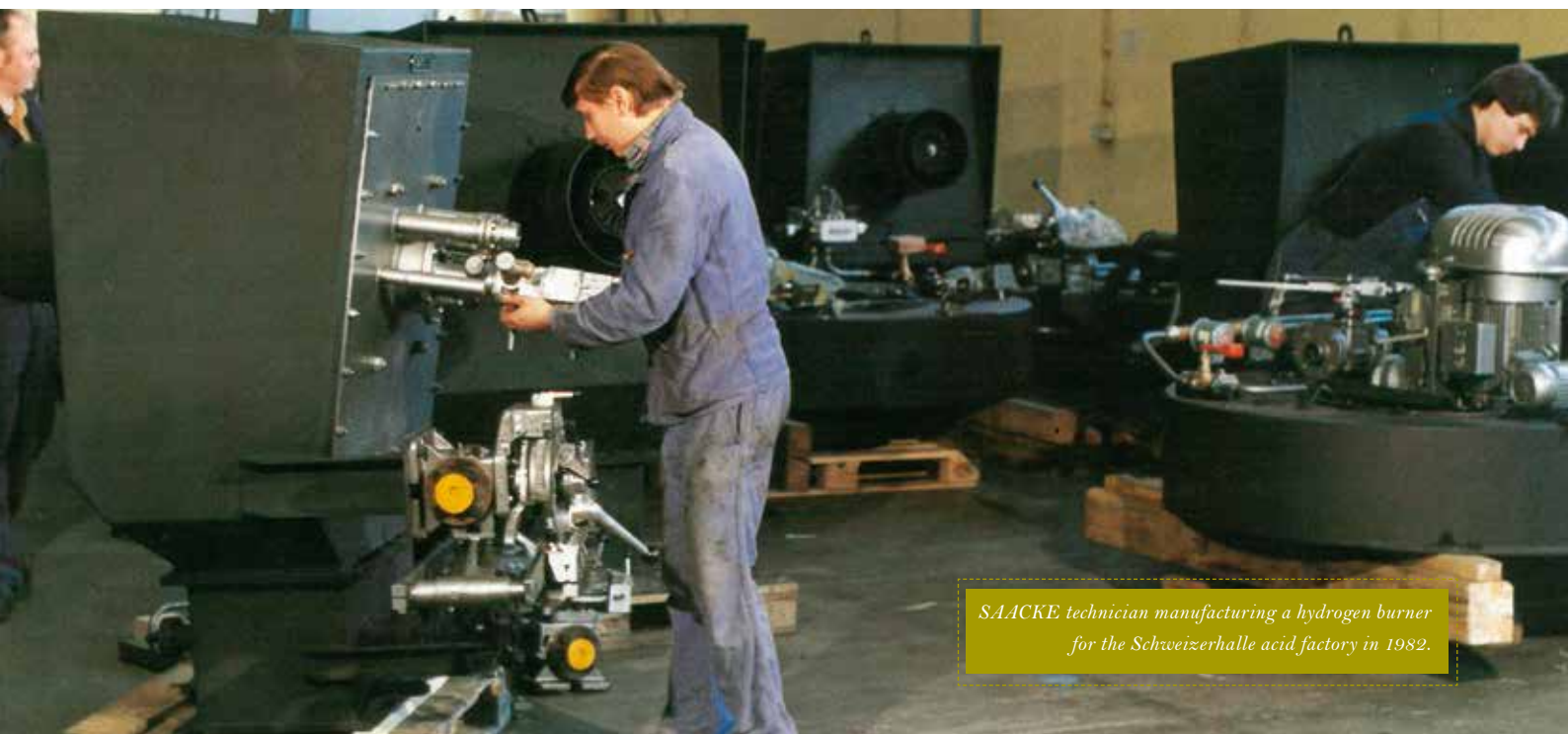

SAACKE technician manufacturing a hydrogen burner for the Schweizerhalle acid factory in 1982.

Conclusion and outlook

Hydrogen is the ideal energy source for the transition to a carbon-neutral future, without compromising flexibility, safety, efficiency and performance. But the good news is that the proven technology is already available now and can be used immediately! Do not hesitate and get ready for the clever and cost-saving recycling of residual H₂ in the production process or the increasing large-scale feeding of hydrogen into existing natural gas pipelines. Avoid time-consuming conversions when it is too late and ensure the future viability of your plants.

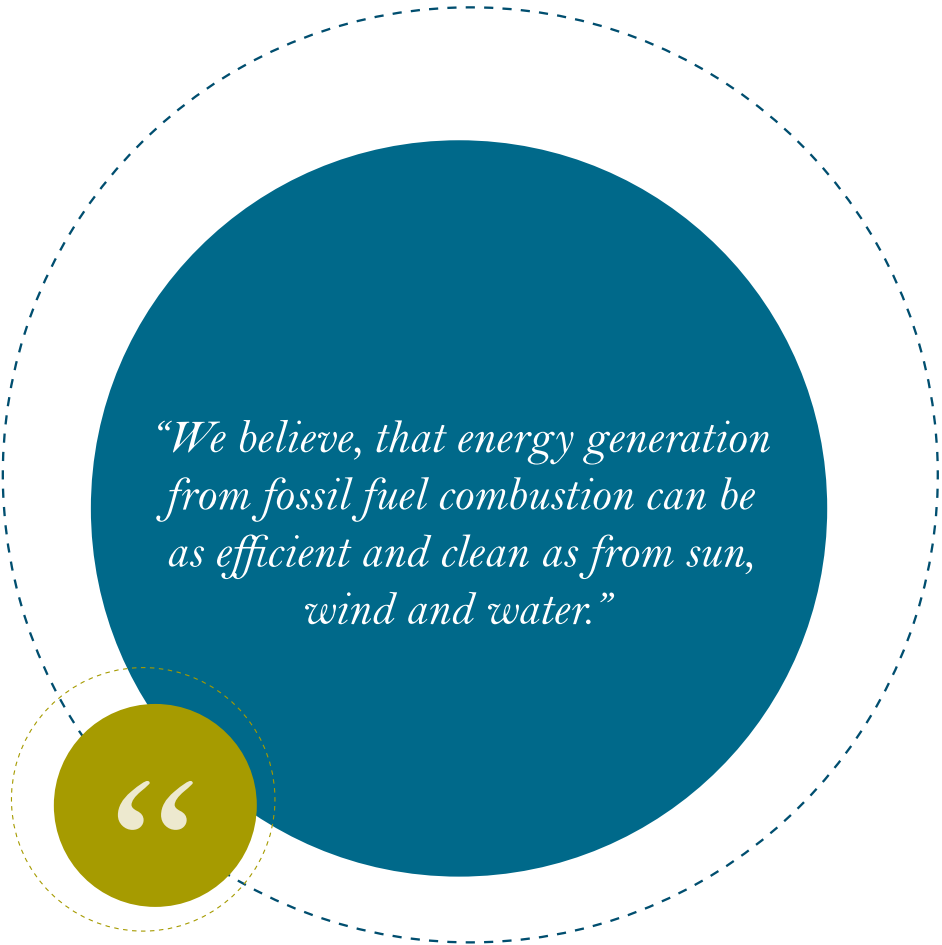

“We believe, that energy generation from fossil fuel combustion can be as efficient and clean as from sun, wind and water.”

Who we are

SAACKE GmbH specializes in thermal processes and plants in industrial and maritime energy management. In these fields, we are among the world market leaders. We have been developing modern combustion systems, which can also process **hydrogen** efficiently and safely, since the early 1980's.

Founded in 1931, we are still a medium-sized family business today and employ a total of around 1,200 people - including a good 450 engineers and technicians. We have production sites in Bremen, Croatia, China and Argentina as well as a worldwide service and sales network. Headquarters, main production and research and development are located in Bremen, northern Germany. We are also a member of a working group of the German Engineering Federation (VDMA), which is concerned with hydrogen or synthetic liquid fuels from surplus electricity generated by wind and photovoltaics (power-to-gas) as well as the intermediate storage of renewable energies.

For more information